

BLUESKIN PRESEAL 320 OR BLUESKIN PRESEAL 435

BLUESKIN PRESEAL 320 OR BLUESKIN PRESEAL 435
(SEE PIPE FLASHING SEQUENCE DETAIL)

WRAP PIPE/CONDUIT WITH
MIRASTOP BW OR MIRASTOP NBW
(SEE NOTE #3)

**BLUESKIN
PRESEAL
TAPE 120V**

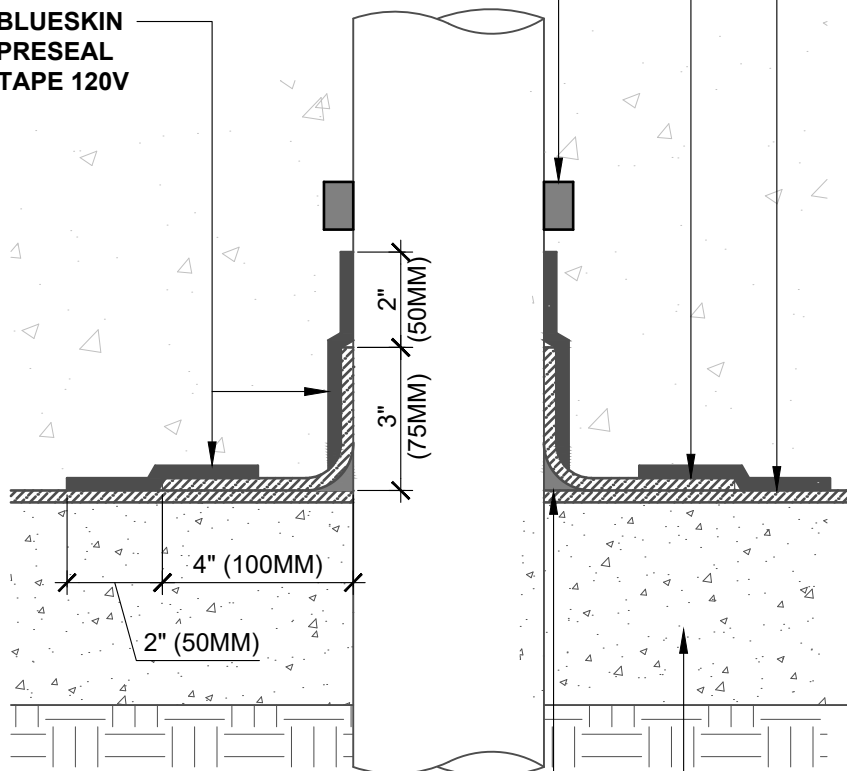

SEAL PIPE WITH A 1" X 1" (25MM X 25MM)
FILLET OF HENRY 925 BES SEALANT

COMPACTED EARTH, COMPACTED STONE,
OR MUD SLAB

1" X 1" (25MM X 25MM)
FILLET HENRY
925 BES SEALANT

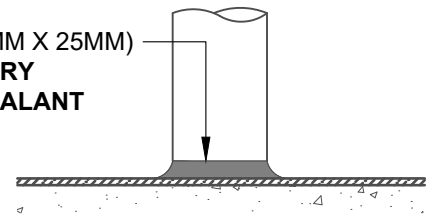

1

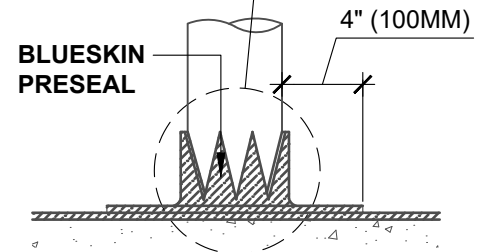
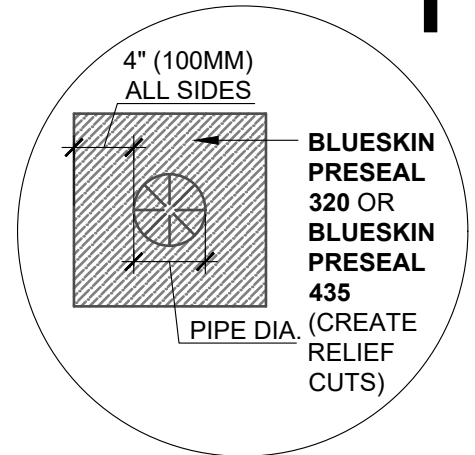

**BLUESKIN
PRESEAL
TAPE 120V**

2

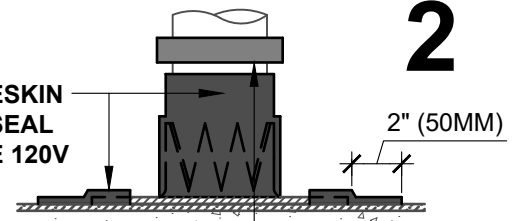

**SYNKO-FLEX WATERSTOP,
MIRASTOP BW, OR
MIRASTOP NBW (SEE NOTE #3)**

3

PIPE FLASHING

ELEVATION VIEW

NOTES:

1. DETAIL SHOWS HENRY PRE-APPLIED WATERPROOFING SYSTEM FOR APPLICATIONS USING HENRY **BLUESKIN PRESEAL 320** OR **BLUESKIN PRESEAL 435**. SUBSTRATE SHOWN IS FOR REFERENCE ONLY.
2. REMOVE DIRT, DEBRIS, RUST AND OTHER CONTAMINANTS FROM PIPE PRIOR TO HENRY 925 BES SEALANT INSTALLATION.
3. APPLICATIONS USING SWELLABLE WATERSTOPS: 3" (75MM) MINIMUM CONCRETE COVERAGE ON ALL SIDES.
4. REFER TO PRODUCT SPECIFIC TECHNICAL DATA SHEET AND GUIDE SPECIFICATION FOR INSTALLATION PROCEDURES.



MANUFACTURER GUIDE DETAILS ARE FOR REFERENCE ONLY. HENRY DOES NOT ASSUME RESPONSIBILITY FOR ERRORS OR DEVIATIONS IN DESIGN OR ENGINEERING. PROJECT SPECIFIC VERIFICATION IS RECOMMENDED PRIOR TO INSTALLATION.

HENRY PRE-APPLIED WATERPROOFING SYSTEM

SLAB PENETRATION

**BLUESKIN PRESEAL 320 OR BLUESKIN PRESEAL 435
PIPE OR CONDUIT**

SCALE: N.T.S.

11-06-2023

BSPS-9B.2