

ASTM E2112 - METHOD A

FLASHING INSTALLED BEFORE WRB

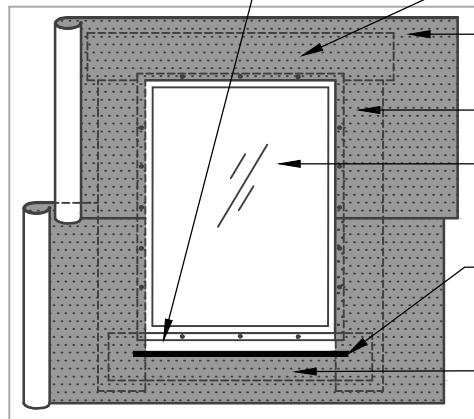
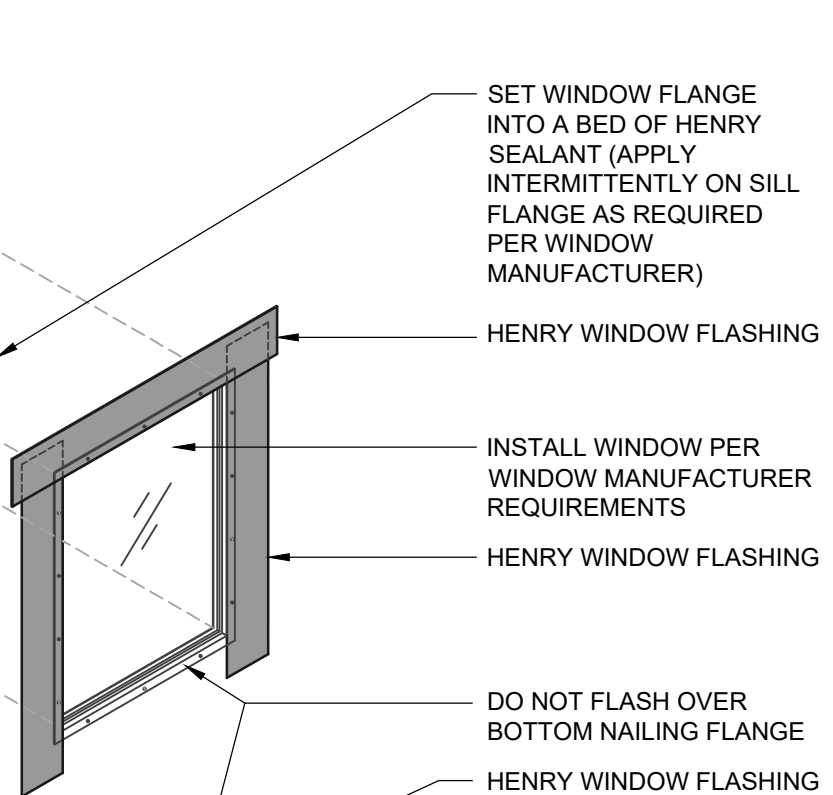

ASTM E2112 - METHOD A (ELEVATION)

FLASHING INSTALLED BEFORE WRB

Henry WATER RESISTIVE BARRIER (WRB) ASSEMBLY

HENRY WATER RESISTIVE AIR BARRIER
• BLUESKIN METAL CLAD
HENRY WINDOW FLASHING
• BLUESKIN METAL CLAD
HENRY SEALANT
• HENRY 925 BES SEALANT
• AIR-BLOC LF

NOTES:

1. DETAIL SHOWS **BLUESKIN METAL CLAD SELF-ADHERED WATER RESISTIVE AIR BARRIER**. SUBSTRATE SHOWN IS FOR REFERENCE ONLY. ACCEPTABLE SUBSTRATES INCLUDE PLYWOOD, OSB, CONCRETE, CMU, METAL, AND EXTERIOR GRADE SHEATHING.
2. SELF-ADHERED MEMBRANE PRIMER NOT SHOWN FOR CLARITY.
3. OTHER FLASHING OPTIONS INCLUDE: **BLUESKIN BUTYL FLASH, BLUESKIN SA OR BLUESKIN SA LT.**
4. HENRY WINDOW FLASHING DETAILS ARE BASED ON ASTM E2112. ACTUAL CONDITIONS MAY VARY. VERIFY PROJECT SPECIFIC WINDOW INSTALLATION REQUIREMENTS AND FLASHING COMPATIBILITY WITH DESIGN PROFESSIONAL.
5. REFER TO PRODUCT SPECIFIC TECHNICAL DATA SHEET (TDS) AND **BLUESKIN METAL CLAD** GUIDE SPECIFICATION FOR INSTALLATION PROCEDURES.



999 N. Pacific Coast Highway, Suite 800
El Segundo, CA 90245
800-486-1278 • www.henry.com

MANUFACTURER GUIDE DETAILS ARE FOR REFERENCE ONLY. HENRY DOES NOT ASSUME RESPONSIBILITY FOR ERRORS OR DEVIATIONS IN DESIGN OR ENGINEERING. PROJECT SPECIFIC VERIFICATION IS RECOMMENDED PRIOR TO INSTALLATION.

BLUESKIN METAL CLAD SELF-ADHERED AIR BARRIER

FLANGED WINDOW

**ASTM E2112 METHOD A
FLASHING INSTALLED BEFORE WRB**

SCALE: N.T.S.

01-09-2020

MTLCLD-6A-B