

PRETREAT DRAIN AREA WITH SEALANT EXTENDING FLASHING TO THE DRAIN HOLE OPENING PRIOR TO COATING INSTALLATION USING ONE OF THE SEALANTS BELOW (125 WET MILS):

- PRO-GRADE® 920
- PRO-GRADE® 923
- PRO-GRADE® 957

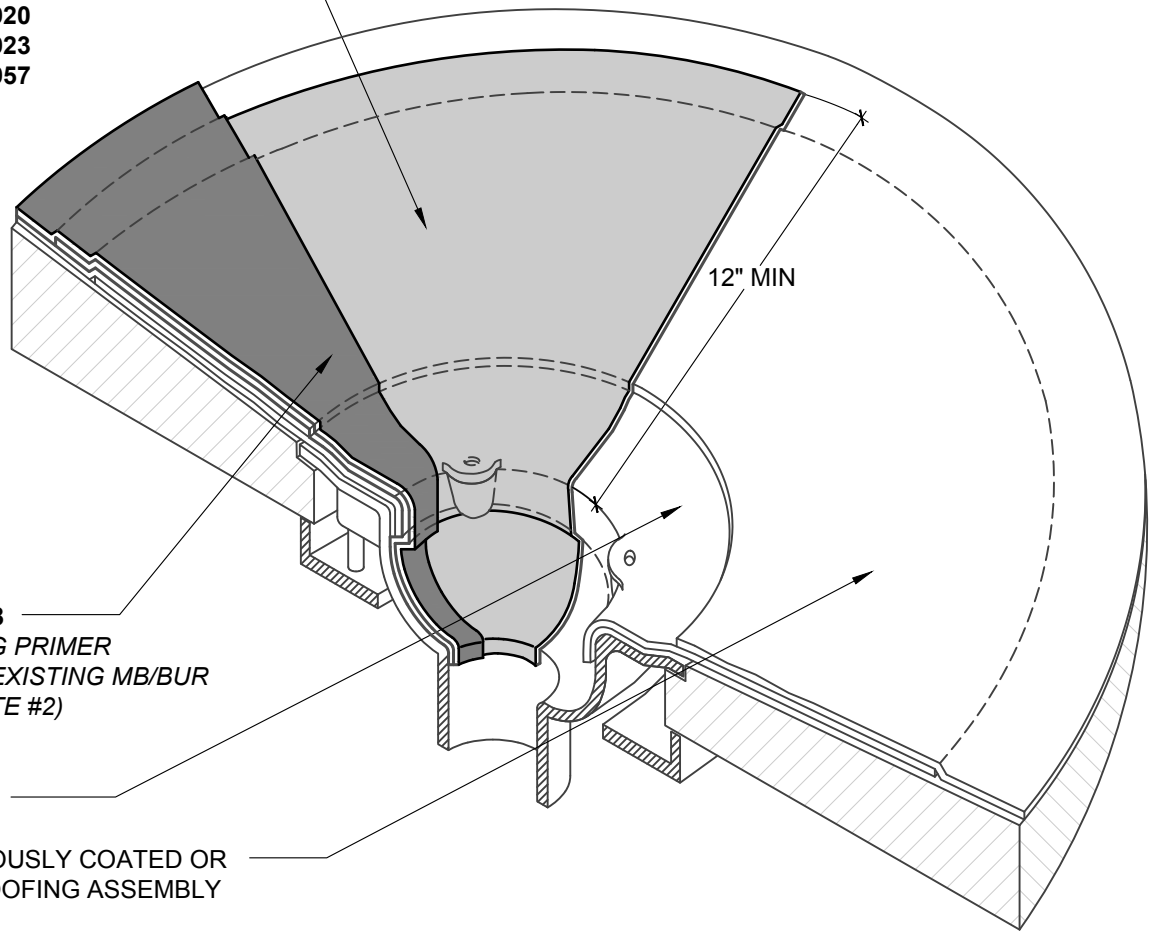

**PRO-GRADE® 988**  
(STAIN BLOCKING PRIMER  
REQUIRED FOR EXISTING MB/BUR  
ROOFS -SEE NOTE #2)

EXISTING DRAIN

EXISTING PREVIOUSLY COATED OR  
NON-COATED ROOFING ASSEMBLY

**NOTES:**

1. DETAIL SHOWS **PRO-GRADE® 988** INSTALLED OVER AN EXISTING PREVIOUSLY COATED OR NON-COATED ROOFING ASSEMBLY. ACCEPTABLE SUBSTRATES INCLUDE GRANULATED OR SMOOTH SURFACED MODIFIED BITUMEN (MB), SMOOTH SURFACED ASPHALT BUILT-UP ROOFING (BUR), AGED EPDM, PVC, HYPALON® OR TPO.
2. INSTALL **PRO-GRADE® 294** STAIN BLOCKING PRIMER ONTO EXISTING MB/BUR ROOF PRIOR TO FLASHING/COATING INSTALLATION (STAIN BLOCKING PRIMER NOT SHOWN FOR CLARITY).
3. REMOVE STRAINER, RING AND OTHER DETAIN COMPONENTS PRIOR TO COATING INSTALLATION.
4. COMPLETE ALL DETAILING PRIOR TO INSTALLATION OF ROOF COATING.
5. DECK AND EXISTING ROOFING ASSEMBLY SHOWN ARE FOR REFERENCE ONLY.
6. REFER TO **PRO-GRADE® 988** GUIDE SPECIFICATION, INSTALLATION MANUAL AND/OR APPLICATION GUIDE FOR RECOMMENDED INSTALLATION PROCEDURES.
7. REFER TO **PRO-GRADE® 988** WARRANTY CHART FOR SUBSTRATE SPECIFIC FIELD COATING MINIMUM REQUIREMENTS.

**Henry®**

999 N. Sepulveda Blvd., Suite 800  
El Segundo, CA 90245  
800-486-1278 • www.henry.com

MANUFACTURER GUIDE DETAILS ARE FOR REFERENCE ONLY. HENRY® DOES NOT ASSUME RESPONSIBILITY FOR ERRORS OR DEVIATIONS IN DESIGN OR ENGINEERING. PROJECT SPECIFIC VERIFICATION IS RECOMMENDED PRIOR TO INSTALLATION.

**PRO-GRADE® 988 SILICONE ROOF COATING**

**ROOF DRAIN**

ROOF DRAIN ON A MEMBRANE ROOF  
[NO STRAINER/CLAMPING RING SHOWN FOR CLARITY]

SCALE: N.T.S.

06-20-2017

**PG988-9A**