

**PUMADEC™ FLEX 30SL REINFORCED
WITH PUMADEC™ N-FLEECE**

**PUMADEC™ PRIMER 20
OR HENRY® GC PRIMER**

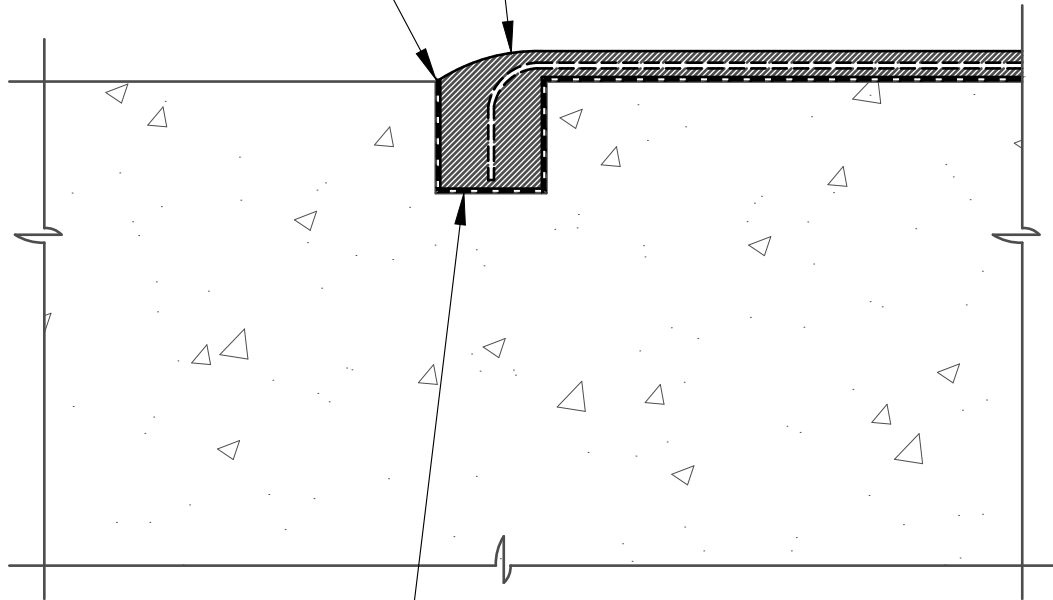

**CUT 1/2" X 1/2" MINIMUM REGLET
INTO DECK TO FUNCTION AS
WATERSTOP WHERE
WATERPROOFING ENDS**

NOTES:

1. DETAIL SHOWS HENRY® **PUMADEC™** SYSTEM WATERPROOFING ASSEMBLY WITH A REINFORCED FIELD MEMBRANE. SUBSTRATE SHOWN IS FOR REFERENCE ONLY. REFER TO PRODUCT SPECIFIC TECHNICAL DATA SHEET FOR AUTHORIZED SUBSTRATES.
2. DO NOT INSTALL **PUMADEC™** SYSTEM BEYOND PRIMED SURFACES.
3. HENRY® OFFERS PAVERS, RIGID INSULATION, AND/OR PREFABRICATED DRAINAGE COMPOSITES AS A SINGLE SOURCE WARRANTY OPTION PER PROJECT SPECIFIC REQUIREMENTS (NOT SHOWN FOR CLARITY). CONTACT HENRY® FOR SYSTEM CONFIGURATIONS AND WARRANTY OPTIONS.
4. REFER TO **PUMADEC™** SYSTEM GUIDE SPECIFICATION FOR RECOMMENDED INSTALLATION PROCEDURES.

Henry®

999 N. Pacific Coast Highway, Suite 800
El Segundo, CA 90245
800-486-1278 • www.henry.com

MANUFACTURER GUIDE DETAILS ARE FOR REFERENCE ONLY. HENRY® DOES NOT ASSUME RESPONSIBILITY FOR ERRORS OR DEVIATIONS IN DESIGN OR ENGINEERING. PROJECT SPECIFIC VERIFICATION IS RECOMMENDED PRIOR TO INSTALLATION.

PUMADEC™ SYSTEM - WATERPROOFING ASSEMBLY

**SUBSTRATE TERMINATIONS
REINFORCED FIELD MEMBRANE
TERMINATION ON HORIZONTAL SUBSTRATES**

SCALE: N.T.S.

04-26-2019

PUMADEC-T2A